

# **If science was been globally applied, current energies and depurations would not have a future**

**If science was been globally applied, current energies and depurations would not have a future**

(Fourth Letter to the International Courts of Justice)

Abstract

I think that at the point where it is useless to run politicians, entrepreneurs, economists, authorities of the environment and energy. The only ones who can claim the scientific truth are the International Judges, appointing special commissions. But, certainly, the commissions have an economic cost. I do not know if Judges have a sufficient budget for such inquiries. I do not even know if they can, investigate on the basis of simple open letters and documents published by the undersigned. For the moment even the International Judges are silent.

One thing is certain, since the advent of the industrial age, environmental science has never been applied globally, both when making depuration, both when producing energy, both when performing other human activities. In tutti i settori si lavora a compartimenti stagni senza creare collegamenti e sinergie con l'ambiente circostante. In all sectors, you work in watertight compartments without creating connections and synergies with the surrounding environment. The undersigned who has proposed to the world the chimneys recovering heat and CO<sub>2</sub>, the water and air sewage gutters, the limestone greenhouses that would produce oxidized and alkaline waters by cold consumption of CO<sub>2</sub> in the same urban centers, is

considered a person who can not lose it sportily, if the world's most democratically-constituted world of science and technology does not consider its solutions. It does not matter if at least 99% of that majority can not freely express their opinion, being constrained by corporate loyalty, rightly so, claim public and private employers. In other words in terms of environment and energy, only delegated directors have decision-making powers. All others do not count, they simply keep the company positions in the best interests of the company they belong to. The end justifies the means. The end is business survival, the means of defense is silence. Therefore, even CEOs respond to those shows, with new solutions, which since the advent of the industrial age have been made poor choices on energy and environmental terms. New solutions must be demonstrated. Who can show them if everyone keeps silence?

The highly detailed scientific information on pollution issues and alarms from environmental associations, writers and opposition politicians, including former vice president Al Gore, awarded with the 2007 Nobel Prize for my undersigned, Contrary to what they want, because they make more funds available for the environment and research, but investments and research do not change the direction in which previous investments took place. Consequently, if technical and scientific mistakes were made in the initial setting of global purification and energy development, no one can perceive it. More investments are made in areas that have already given their full potential without getting great results, the more they subtract resources to alternative solutions that have never been developed, which are more likely to succeed. Obviously, I am talking about my solutions to fossil energy cleanup, as mentioned above, democratically ignored by public executives who follow the laws of politics and the private ones that follow the laws of the market. The limits of current public and private delegated directors are immense because public ones have a wrong environmental model and private ones,

an industrial development model partially wrong, as it is not correct by public environmental directives. Just think about the automotive industry, which is the most up-to-date and efficient in the world, which has failed to focus on the thermal engine. The same was done by the aeronautical and naval industry. The limits of current world CEOs are due to the limits imposed by scientific and technological research to defend the scientific and technological choices made previously, on which the current world economy is obviously based. How can current global, public and private delegated directors recognize the value of interactive water-to-air energy that, without fuels, avoids CO<sub>2</sub> emissions and even oxidizes the waters, which can be produced at all times of the day and of the night, with any terrestrial temperature, and which you can also be fitted on the means of transport? Where did this energy come from, if none of them financed it? Who has betrayed the orders received? World CEOs are quiet. Nobody betrayed them but they were unable to prevent solutions that they have discarded on fossil energy clean-up, and make other ideas on low-cost water and air recycling, which have led to the interactive energy between water and Air that does not emit CO<sub>2</sub> and thin dust, consuming only material wear, can be at least 2.5 times more powerful than fossil, simply using better physics and current technologies.

## Description

I provide new details of compressed hydroelectric energy, which is not easy to understand only from descriptions, but who has no other means of expressing, can only try to find the right words to clarify possible doubts.

The compressibility of atmospheric air does not significantly deviate from Boyle's law (at constant temperature for a fixed mass, the absolute pressure and the volume of a gas are inversely proportional). Only at very high pressures, above 2790 bar, the air is a little less compressed than the law.

Air unlike other gases, such as carbon dioxide, ammonia, chlorine, and so on despite high pressures, it maintains the gaseous state. In fact, all gases are capable of assuming the liquid state under a given pressure, provided that they are brought below a certain temperature (different for different gases) called critical temperature. The failures encountered in the first attempts to liquefy air (and also oxygen, hydrogen, nitrogen and other gases) were due only to the fact that these gases have a very low critical temperature (about air around  $-140^{\circ}\text{C}$ ), much lower than the gas reaches during compression, which produces heat.

This particular feature, combined with the incompressibility of water is an infinite energy source, free and much more powerful than thermal energy, but could not be used without the invention of the pump with the double separate suction supply until the impeller. In fact, with this pump, the suction side of the impeller is balanced by the pressurized supply pressure with the compressed air and on the other side of the suction side the water is in low pressure (at atmospheric pressure). This system, which allows the recovery and pressurizing water at low cost, despite the simplicity, allows to develop in a simple way, the energy system, powerful and clean most of all time.

It should not be forgotten that temperatures in the current heat engines are about  $1200^{\circ}\text{C}$  and pressures of about 40 bar. What produces energy is not the temperature but the pressure and the gas flow that drives the cylinders or passes through a gas turbine. This system, despite a century and a half of worldwide experiments and improvements, in addition to polluting sulfur, nitrogen, lead, carbon, fine dust and  $\text{CO}_2$  emissions, does not exceed 35% lower fuel power. While in compressed air pressurized hydropower plants, we can choose, on a case-by-case basis, the working pressure, the minimum required in domestic installations, to the maximum in means of transport, especially aircraft, to reduce the weights and the

size of the Plants that produce energy with only water and air. As we have said above, we can achieve very high static pressures (above 2790 bar), but if we stop at only one hundred bars allowed by the state of the art of multistage pumps that can be used as turbines, we can already say that hydro-electric pressurized air systems compressed without fuel and without pollution, have the potential to be at least 2.5 times more powerful thermal energy, only according to the ratio of the working pressures usable current state of the art (100/40). But these plants are also less bulky without needing tanks with thousands of pounds of fuel, among other things, bought at a fair price. The means of transport will not need to stop at distributors along the streets or intermediate airports to fill the tanks. While ships will not need large tanks for diesel fuel.

In these systems, you should not be afraid of high pressures because they are static pressures that solicit only the outer casings of the pumps and tanks. The impeller of the pump with the double separate supply until the impeller is unstressed, working with the balanced pressure in suction and discharge. While for multistage pumps used as turbines, only the first impellers are used at maximum pressure, as pressure drops from one stage to the next. For a lucky circumstance, current technology makes it possible to use multistage pumps as turbines, which with clean water already as written can reach 100 bar pressures. It is obvious that these pumps used as turbines would transform the electric thrust into the impellers on a series, just as when the same pump uses them to raise water, consuming energy instead of producing it. The multistage pumps manufacturers have not yet understood their luck because the multistage pumps, without the new energy application, would be useless, being advantageously replaced by the coupling between the two separate power supply pumps and pressurized tanks, water enable minimum energy consumption, due to the only water recycling. Of course, many other types of pumps will have to be modified and adapted to

the dual supply until the impeller if they want survive.

We use cents or thousands of energy expense for current hydraulic lifting based on accidental leakage losses and pipes and valves. In fact, the lifting of the water will effect the static pressure of the plant, without energy consumption. However, it is necessary to understand that in the circuits that produce pressurized hydropower, through the supply at low pressure of the pump with the double separate supply until to the impeller, can not enter more water than they bait in high pressure through the pump used as a turbine due to the fact that the system always works with the same level of water and air inside the pressurized tank. In fact, if you close the output of the pump used as a turbine, you can not enter water from the low pressure feed for the principle of the impenetrability of the bodies ("If a body made up of matter occupies a space, this space can not be occupied by another body "), while feeding works in high pressure, which is only an internal recycle to the pressurized tank. This means that keeping the plant in operation at all times (with all open power supplies) and coupling to the pump with the dual supply a variable speed motor, we can vary the flow while the pressure is always determined by the air cushion, which always exercises The same water pressure, regardless of whether the outlet to the turbine is open or closed. In fact, with water output to the open turbine, we produce energy and drain the water in low pressure, but at the same time, a corresponding amount of water falls into the pressurized tank through the separate feed of the low pressure impeller Restore the volume of water that was released. Who does not include the operation of such a simple and straightforward installation is anchored to the current operation of the pressurized autoclaves with compressed air, which, not existing pumps with the dual separate supply, must necessarily use the visible expansion of the air cushion to use pressurized water with compressed air. But current autoclaves do not need to save energy and even to produce it, only serve to reduce the number of start-up of the

pump motors and mitigate the phenomena of water hammer. Indeed, in current autoclaves, the air cushion re-compression involves an energy consumption of at least equal to that saved during the expansion phase. In this new system it is not important to expand the air cushion but to circulate the water in the one-way pressurized tank. In reality, expansion exists but is compensated instant for instant by uncompromising water that enters the reservoir again through the second separate feed to the impeller. For this reason, no further pressurization of the air cushion is required and for the same reason there is no energy consumption.

This phenomenal fact of physics and hydrodynamics is due solely to the invention of the pump with the dual power supply until the impeller, which always absorbs the same energy, regardless of the pressure of the air cushion, because with the dual supply it is limited only to enter the water at low pressure, in the internal recycling circuit of the pressurized tank. As this circuit draws and draws recycled water into the accumulated volume, the tank compressed air pillow expels the amount of excess water taken out of the reservoir at the same moment and in equal quantities, because of the above principle of the impenetrability of the bodies. The same occurs in nature when the overflow level of a basin subject to gravity and atmospheric pressure is exceeded, which is still a pressure of about 1,013 bar. If we were to make a pressurized steel bell at a pressure of 11 bar above this basin, the water from the same outlet would come out with a pressure of 10 times higher but would run out in the shortest time without the invention of the pumps with the double separate supply until the impeller which allows to insert in the recycling circuit the water drained, instant by instant. Even in this case the ten bars of higher pressure could be used to produce electricity. However, it would not be very practical pressurization of a hydraulic reservoir, you can achieve the same effects, as indicated by the undersigned: pressurizing the water with air cushions in small stainless steel tanks at

11 bar, immersed in the water, feeding them with the water of the basin and bringing it out in the same basin by the discharge of the pump used as turbines. The same system can be used in domestic and mobile installations recovering the water in an open tank put beside to the one pressurized. In any case, reinsert the water in the pressurized tank at the same instant, in the same amount as the discharge.

This process might seem complicated and require mechanical and electronic synchronism, it is instead a natural process based, as written, on the principle of impenetrability of bodies, namely incompressible water that circulates inside the accumulated volume and is ejected from the static pressure of compressed air (no energy consumption) at the same instant in which exceeds the volume assigned to it. The past and present science did not catch the fleeting moment of connection between the water coming out of the pressurized circuit at the expense of the air cushion without draining it, and the water entering the pressurized circuit again by circumventing its pressure Air cushion by means of the pump with the dual power supply and the internal recycling circuit of the pressurized tank. It would be absurd for world public science to keep silent on these concerns, as it is doing, to foster non-interactive energies between water and air, which are not only polluting but also hundreds of times more expensive.

What are the reasons why, despite not having experienced the system described above, are 100 percent sure it works? The answer is simple, because the use of pumps, compressed air and general plant engineering has been my job throughout the whole working life. I am not interested in the experiences of those who have not come to my own conclusions, which among other things do not contest them. They're just silent. For my part, I am sure that if I as a dependent employee had more chance of working, researching and designing pure, instead of merely executing the orders I received, I could have understood and communicated these inventions long ago, above all, I would be



spared all the work I done as retired to try to clean up the fossil energy that the world's public bodies ignored. Partly they were right. Since the clean and protective energy of the environment does not cost anything. But why did not they seek and continue to hinder her?

Bearing in mind the state of the art operation of the multistage pumps, based not only on the standard arrangement of the impellers, but also on the precision of mechanical machining of the rotating parts, which does not allow the water to go back despite the high pressures, by deduction, it is even less likely that with the pump with the dual power supply up to the impeller, low pressure water can not enter the pressurized recycle circuit, using the same impeller of the pump, has balanced suction pressure and delivery. Indeed, being the hermetically separated feeds, and being the rotating impeller, each sector of the impeller receives, not simultaneously but in succession, high and low pressure water, which go in the same direction, determined by the direction of rotation of the impeller itself. Therefore, the water introduced with less pressure is pushed to the output of the impeller from the recycled water inside the pressurized circuit which is equipped with a higher static pressure. This is also confirmed by the principle of Pascal, which states that in a closed tank (to which the pump body can be assimilated after the impeller) the pressure expands in all directions. As for the use of pumps as turbines, it has already been extensively tested by the same pumps manufacturers.

With a variable speed motor coupled to the pump with the dual supply until the impeller, we can establish, instantaneously, the amount of energy the turbine coupled alternator must produce, depending on the power used for the plant. We do not consume fuels, lubricating oils, water and air (apart from the one that dissolves positively in water with depurative oxygenation effects, proportionally to pressure, according to

Henry and Dalton's principles). What do we use to produce energy? Only the wear of materials, especially of rotary machines (pumps, turbines, motors and alternators, only in small part the compressors).

This is certainly the energy that will bring greater fairness in the distribution of world wealth, as it is cost-free from industrial, urban, agricultural users, apart from the purchase of plants and means of transport and labor. No large power plants and distribution networks will be more necessary, that have high costs, dimensions, involving about 12% of the energy losses, and produce blackouts in case of overload. Hence, the facilities will be within the reach of small and medium-sized businesses. Multinationals will only have to limit themselves to producing large-scale components (Pumps, turbines, compressors, motors, alternators, inverters, means of transport, agricultural and work vehicles, as written, with much more powerful and economical compressed hydroelectric engines than current heat engines) Of any type and size.

In the absence of simple interactive energy between water and air, which with hindsight, could be born at the beginning of the industrial age, the world public bodies and multinationals of large nuclear and thermal hydraulic works, have created more disasters that benefits to the environment and the world economy. As fossil energy warmed the planet, nuclear disasters did their part, the great works, above all, hydraulics that favored drought and floods. The story will show what will be the best energy for everyone. I do not have the slightest doubt, but small and medium-sized businesses, environmental associations, the poor, the unemployed, if they want their energy to win, they have to give up. They can not continue to leave all the designs in the hands of those who have shown that they do not understand the needs of the territories by designing incomplete energy and purification systems that do not close the cycles they open.

World science, which in terms of energy has gone wrong, is now

climbing on mirrors with nonsense batteries, which require energy storage and a dedicated recharging network that stops cars for many hours at very high costs compared to cars Hydroelectric plants that would have endless autonomy producing small energy bulk on board the vehicle. It also climbs on the mirrors, also by stimulating solar panels that require at least 10 square meters of daily latitude and longitude to produce a KW/h, while wind power to concentrate the specific pressure of 0.83 bar on the turbine blades requires a Wind of about 80 km / h. It climbs on the mirrors even by burning up the biological energy without requiring heat recovery and carbon cycle closure (<http://www.spawhe.eu/the-role-of-biological-energy/>)

Public medical science is making giant steps in the fight against diseases and cancers, while environmental and energy issues insist on obsolete projects and even sells their patents to private companies. He ignored the undersigned solutions for the cleaning of fossil energy and the change of municipal purification systems through the chimneys and purifying sewer. Today, he refuses to understand the natural synchronism that would produce compressed hydroelectric energy, which would even oxygenate the water in wells, basins, lakes and seas. While the most pressurized versions with very low costs could be used on all types of mobile vehicles and on the means of work of the earth and on fire-fighting tools, such as canadairs, which could be conceived, even in an urban version, rising vertically in Space, thanks to the energy that costs nothing.

Even today, the interactive energy between water and air, it cannot count on only one euro of funding. The state of virtual art that has led the undersigned to claim that the current state of the art has the potential of this energy to be 2.5 times higher than thermal energy, regardless of the economic and environmental aspect, is due to the virtual use of existing technologies in other areas, which are not properly

exploited today, coupled with the never-funded inventions of the undersigned. These inventions have grown only virtually on the basis of the global engineering experience and reasoning that today all job-seekers do not want to experiment, being used to working in stagnant compartments, starting from universities, public and private research institutions, such as public and private companies. Taylorism and labor organization, which at least at industrial level has multiplied the productivity of the main consumer goods, do not want to apply it to the environment because it would point out incomplete cycles and poorly proportioned energy and deputy installations built throughout the world.

The current global organization of work and the economy is managerial, could be fine to handle routine administration problems after reached a sustainable development model, non-polluting and environment protection. Today, however, we have a pollutant development model, unsustainable and eighty percent of the world's population is below the subsistence level, mainly because of the fact that science and technology working in isolated compartments take for granted the progress of the art of individual sectors that in reality are incomplete because they do not complete the chemical and biological cycles that open in all human activities. Only the interactive, cost-effective energy that protects the environment wherever it is produced can remedy this world disaster.

Lawmakers, who are not engineers and scientists, have always trusted and swear by energy and incomplete purification projects. Such solutions are also exported to developing countries. Today, all the countries are copying each other, assuring that the most developed countries have already chosen the best solutions, but in many cases they have chosen the worst and technology can not improve them anymore because environmental, energy and purifiers should be designed globally without ever opening cycles that you are not able to

close in the same plants. Do not scientists know that CO<sub>2</sub> can only be chemically neutralized and with bulky solutions that can not be achieved on the means of transport? Why they have allowed and allow the circulation of billions of vehicles on earth in the sea and in space vehicles that emit CO<sub>2</sub>? Why did not they fight to eliminate the emissions at least in fixed installations, where it would be possible, with cold inorganic cycles, as the undersigned has demonstrated, through small and large limestone greenhouses with water recycling and artificial rainfall?

([Http://www.spawhe.eu/synergic-plants-italian-files/](http://www.spawhe.eu/synergic-plants-italian-files/)). Certainly this is not the solution to be used in mobile systems, but just as well, the undersigned studying it, in-depth studies to save the energy needed in the circulation of water and air to be purified, unexpectedly found themselves inventing Many water-to-air interactive energy solutions, including compressed hydroelectric engines usable on the means of transport. Inventions are made with little successive steps, if no one has tried to save energy by reclaiming water and purifying air at the same time, no one could come to conceive the compressed hydroelectric power that uses static air pressure, adding energy savings to another, in addition to the purifying effect produced by Henry and Dalton.

But

Luigi Antonio Pezone

a)

**IF SCIENCE WAS BEEN GLOBALLY APPLIED, CURRENT ENERGIES AND DEPURATIONS WOULD NOT HAVE A FUTURE**

<http://www.spawhe.eu>  
**Pressurized system,  
 domestic and shared,  
 for water distribution  
 and production of heat,  
 cold and hydropower**

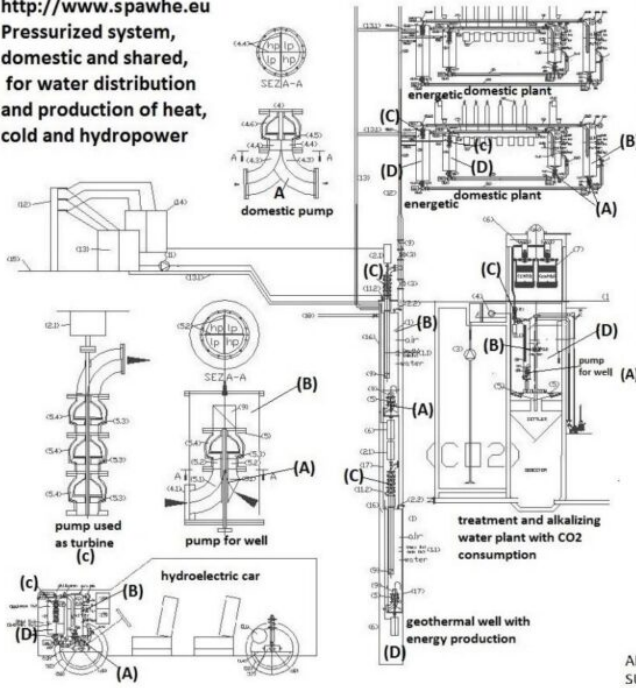

Who asserts that the energy can not be created from nothing does not include that the compressed air is not "nothing." Unlike battery-powered batteries, compressed air can be clamped in a tight volume and work like a compressed spring that transmits its strength to incompressible water, which circles a part of the same, entering and exiting from the same volume, by means of a pump with the dual power supply separated until the impeller, which allows this operation by spending very little energy because the water, being incompressible, in the rotating impeller, sums the two flow rates with a single pressure, which is that of compressed air. However, it can produce electricity through a hydraulic turbine under the thrust of compressed air imprisoned that is not consumed. Since the energy produced by the turbine (which depends on compressed air pressure) is hundreds of times higher than that consumed by the pump (which recycles the water inside the accumulated volume), this system is fully autonomously energetically. I would be curious to watch a speed and power race between a car with statically pressurized hydroelectric power at 100 bar and another with dynamically pressurized 40 bar heat engine, which may not exceed (that has received over one hundred and fifty years of refinements throughout the world). If mathematics and physics are not mere opinions, the internal combustion engine has no hope of winning even on power-up, after being defeated in economic and environmental terms. Obviously, the race could take place in a few years if anyone in the world pulls out the money for testing, fine tuning, and the choice of lighter materials because current hydraulic systems use very heavy materials. Certainly not suitable for land and air transport.

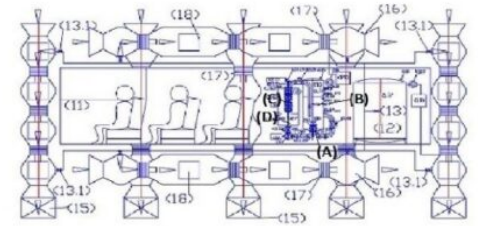

**AEROSPATIAL VEHICLE WITH INTERNAL ELECTRICITY PRODUCTION, POWER SUPPLY OF TURBOFANS IN SERIES AND COMPRESSED AIR INJECTION IN THE SAME TO TRAVEL IN THE SPACE**